



CATCO

CATALYTIC HEATER COMPANY

HEATER ENCLOSURE PACKAGES *For Pipelines*

GENERAL DESCRIPTION

Pipeline Heater Enclosure Packages are used for applying heat to a gas pipeline, generally to control freezing on a regulator, valve or other device from the heater package, located downstream.

Safety

Using the principle of catalytic combustion, catalytic heaters operate at a surface temperature of 600-800 F°, much lower than an open flame (approximately 1300 F°). They are a safe source of heat in areas where there are potential fire hazards from combustible gasses or liquids. They

DESIGN CONSIDERATIONS

Although less efficient than enclosure packages that apply heat directly, pipeline packs are often used to heat gas upstream of valve or regulator. Common applications include situations where the appliance is obstructed in some way, or where the unit must be frequently adjusted or serviced.

- Design of pipeline heater package accommodates all standard pipe sizes through 6".

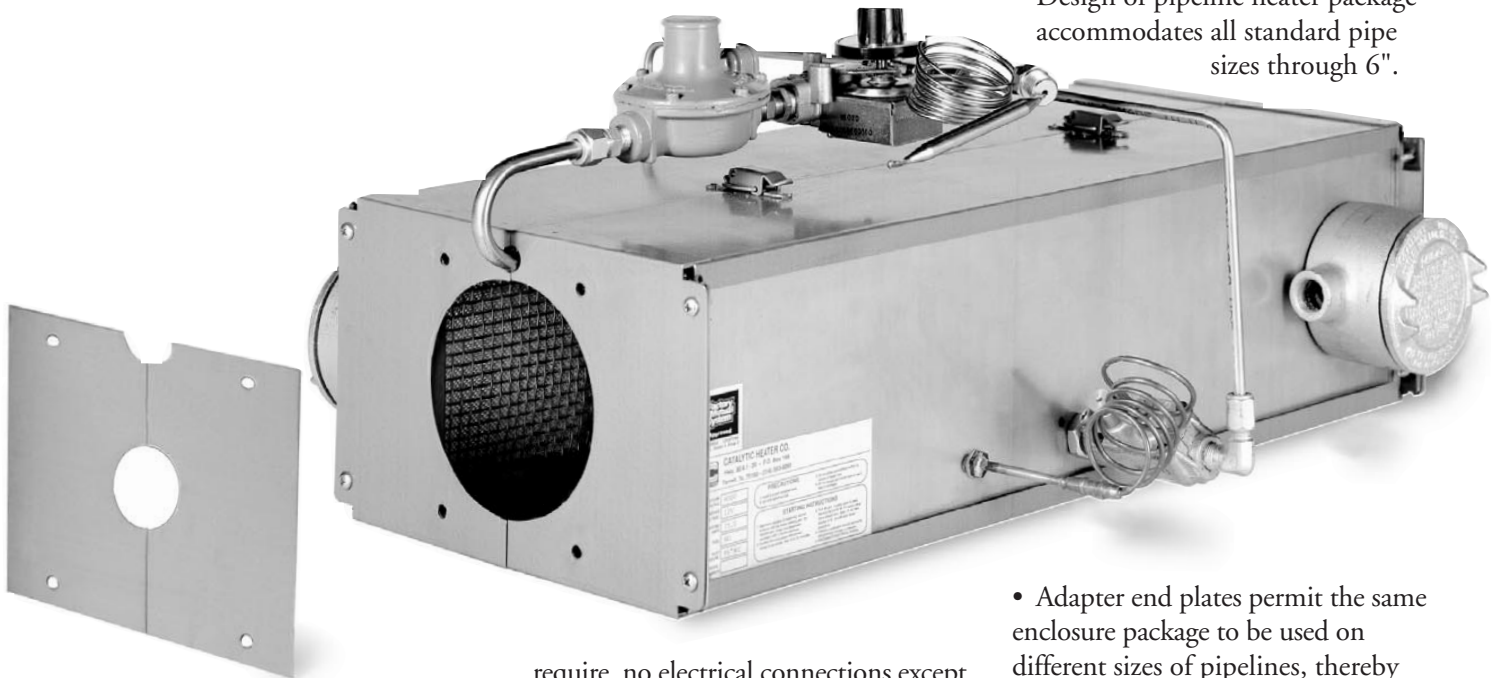

- Adapter end plates permit the same enclosure package to be used on different sizes of pipelines, thereby reducing inventory requirements for heater enclosure packages.

ADVANTAGES OF CATALYTIC HEAT

Efficiency

Catalytic heaters generate radiant (infrared) energy which can be directed on a particular object or target. Energy is not wasted on heating other objects or the air surrounding them.

require no electrical connections except at startups, eliminating frayed wires and short circuits.

Simplicity

Catalytic heaters contain no moving parts and, once energized, will function indefinitely as long as adequate supplies of air and clean fuel are provided. These factors make catalytic heaters ideal for remote applications.

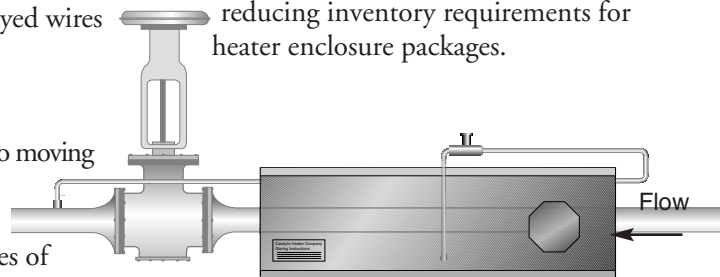

Typical pipeline heater enclosure package.

Available Models

Model 70-045

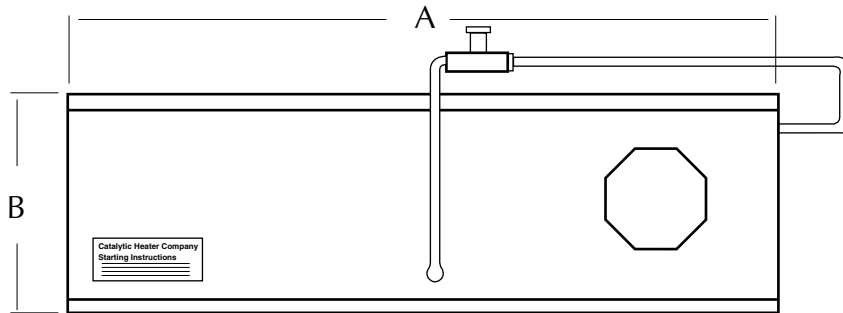

Side View

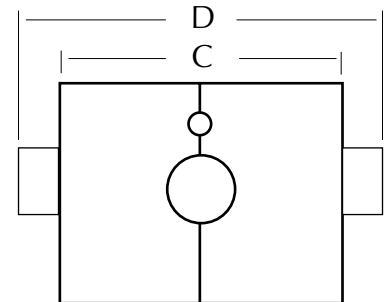

End View

In a Hurry?

Normally, CATCO ships stock enclosure packages next day, and custom designs within a week.

CATCO enclosure packages are designed for easy installation with a minimum of tools required. In most cases installation is simply a matter of snapping the enclosure package around the appliance or pipe and supplying gas to the heater; screws and loose parts are kept to a minimum. Unless otherwise requested by the user, all parts are shipped with the enclosure package so that the unit is complete and ready to install when received in the field.

The catalytic heaters used in enclosure packages may be supplied with either 12 or 120 volt preheat systems and can be fueled with either natural gas or LPG.

FEATURES

- Designed to clamp directly around a pipeline
- Incorporates either one or two Model 624, 6000Btu/hr catalytic heaters
- Field installation quick and easy: Suitcase style latches attach or detach the package in seconds
- The long, narrow configuration of the heaters used permits the radiant heat to be focused directly on the pipeline, rather than upon the surrounding area
- Available in all standard pipe sizes though 6"

OPTIONS

- Explosion proof junction box
- Regulator manifold for dual heater packages
- Thermostatic controls for regulating heater output
- FM approved heaters for Class I, Div. II areas
- CGA approved heaters for Class I, Div. I & II areas

Heater				Dimensions (inches)			
Model No.	Heater Size	BTU	No. Used	A	B	C	D
70-045 (1"-3")	624	6,000 -or- 12,000	one -or- two	24.50	6.75	11	15.00
70-045 (4"-6")	624	6,000 -or- 12,000	one -or- two	24.50	8.75	13.00	17.00



PIPELINE PACKAGE UPDATE

CATCO 70-502

FOUR 6x24 HEATERS FOR TOTAL
UNIT OUTPUT OF 24,000 BTU/HR

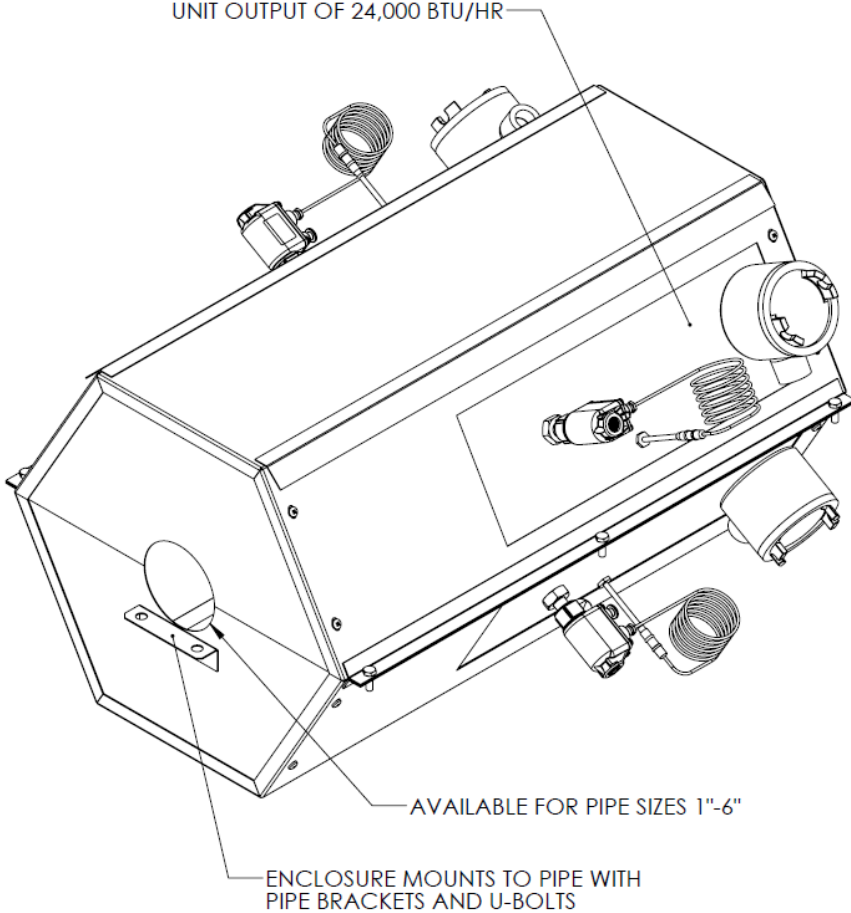

The CATCO 70-502 pipeline package uses many of the same design features and principles of the 70-045, but uses a total of four heaters to introduce more heat in to the gas stream. Due to its efficient use of space and easy installation, the 70-502 has quickly become a preferred method of heating for Pipeline companies, compression companies and production companies.

